

VOLVO PENTA INDUSTRIAL DIESEL

TAD734GE

250kW (340 hp) at 1500 rpm, 263 kW (358 hp) at 1800 rpm

NEW!

The TAD734GE is a powerful, reliable and economical Generating Set Diesel Engine built on the dependable in-line six design.

Durability & low noise

Designed for easiest, fastest and most economical installation. Well-balanced to produce smooth and vibration-free operation with low noise level.

To maintain a controlled working temperature in cylinders and combustion chambers, the engine is equipped with piston cooling. The engine is also fitted with replaceable cylinder liners and valve seats/guides to ensure maximum durability and service life of the engine.

Low exhaust emission

The state of the art, high-tech injection and charging system with low internal losses contributes to excellent combustion and low fuel consumption.

The TAD734GE complies with EU Stage 2 exhaust emission regulations.

Easy service & maintenance

Easily accessible service and maintenance points contribute to the ease of service of the engine.

Technical description

Engine and block

- Optimized cast iron cylinder block with optimum distribution of forces
- Piston cooling for low piston temperature and reduced ring temperature
- Drop forged steel connecting rods
- Crankshaft hardened bearing surfaces and fillets for moderate load on main and big-end bearings
- Keystone top compression rings for long service life
- Replaceable valve guides and valve seats
- Three PTO positions at flywheel end
- Lift eyelets
- Flywheel housing with connection acc. to SAE 2
- Flywheel for flexplate
- Fixed integrated radiator front engine suspension
- Transport brackets, rear

Lubrication system

- Full flow cartridge insert filter
- Rotary displacement oil pump driven by the crankshaft
- Deep front oil sump
- Oil filler on top
- Oil dipstick, short in front
- Integrated full flow oil cooler, side-mounted

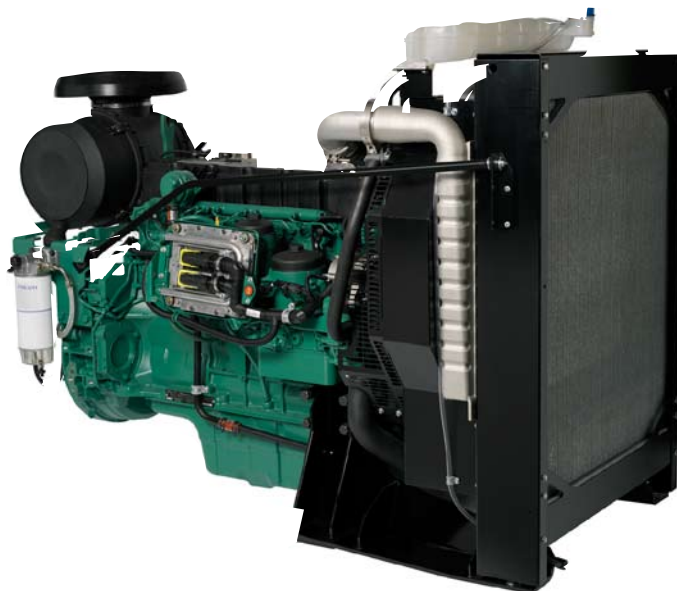

Features

- Electronic governing, EMS2
- CAN bus communication
- Compact design for the power class
- High power to weight ratio
- Emission compliant
- Noise optimized engine design
- Dual speed

Fuel system

- Common rail
- Gear driven fuel feed pump
- Six hole fuel injection nozzles
- Electronic governor
- Fuel prefilter with water separator
- Fine fuel filter of cartridge insert type

Intake and exhaust system

- Connection flange for exhaust line
- Waste gate turbo charger, centre low with exhaust flange
- Two-stage air filter, with cyclon
- Heater flange in charge air inlet (with relay)

Cooling system

- Belt driven, maintenance-free coolant pump with high degree of efficiency
- Efficient cooling with accurate coolant control through a water distribution duct in the cylinder block
- Reliable thermostat with minimum pressure drop

- Pusher fan

Electrical system

- Engine Management System 2 (EMS 2), an electronically controlled processing system which optimizes engine performance. It also includes advanced facilities for diagnostics and fault tracing
- The instruments and controls connect to the engine via the CAN SAE J1939 interface, either through the Control Interface Unit (CIU) or the Display Control Unit (DCU). The CIU converts the digital CAN bus signal to an analog signal, making it possible to connect a variety of instruments. The DCU is a control panel with display, engine control, monitoring, alarm, parameter setting and diagnostic functions. The DCU also presents error codes in clear text.
- Sensors for oil pressure, oil temp, boost pressure, boost temp, exhaust temp, coolant temp, fuel temp, water in fuel, fuel pressure and two speed sensors.

**VOLVO
PENTA**

TAD734GE

Technical Data

General

Engine designation	TAD734GE	
No. of cylinders and configuration	in-line 6	
Method of operation	4-stroke	
Bore, mm (in.)	108 (4.25)	
Stroke, mm (in.)	130 (5.12)	
Displacement, l (in ³)	7.15 (436.0)	
Compression ratio	17:1	
Dry weight, excl. cooling system, kg (lb)	850 (1874)	
Wet weight, excl. cooling system, kg (lb)	910 (2006)	

Performance	1500 rpm	1800 rpm
with fan, kW (hp) at:		
Prime Power	216 (293)	220 (299)
Max Standby Power	241 (327)	247 (336)

Lubrication system	1500 rpm	1800 rpm
Oil consumption, liter/h (US gal/h) at:		
Prime Power	0.01 (0.003)	0.01 (0.003)
Max Standby Power	0.01 (0.003)	0.01 (0.003)
Oil system capacity incl filters, liter	29	

Fuel system	1500 rpm	1800 rpm
Specific fuel consumption at:		
Prime Power, g/kWh (lb/hph)		
25 %	244 (0.396)	257 (0.417)
50 %	233 (0.378)	237 (0.384)
75 %	217 (0.352)	222 (0.360)
100 %	204 (0.331)	205 (0.332)
Max Standby Power, g/kWh (lb/hph)		
25 %	247 (0.400)	259 (0.420)
50 %	235 (0.381)	239 (0.387)
75 %	217 (0.352)	225 (0.365)
100 %	205 (0.332)	207 (0.336)

Intake and exhaust system	1500 rpm	1800 rpm
Air consumption at 27°C, m ³ /min (cfm):		
Prime Power	16.1 (569)	18.3 (646)
Max Standby Power	16.3 (576)	18.9 (667)
Max allowable air intake restriction, kPa (In wc)	3.0 (12.0)	3.0 (12.0)
Heat rejection to exhaust, kW (BTU/min) at:		
Prime Power	160 (9099)	174 (9895)
Max Standby Power	177 (10066)	189 (10748)
Exhaust gas temperature after turbine, °C (°F) at:		
Prime Power	495 (923)	475 (887)
Max Standby Power	550 (1022)	510 (950)
Max allowable back-pressure in exhaust line, kPa (In wc)	7.5 (30.1)	7.5 (30.1)
Exhaust gas flow, m ³ /min (cfm) at:		
Prime power	33.0 (1165)	37.9 (1338)
Max Standby Power	33.4 (1180)	45.5 (1607)

Cooling system	1500 rpm	1800 rpm
Heat rejection radiation from engine, kW (BTU/min)		
Prime Power	23 (1308)	24 (1365)
Max Standby Power	26 (1479)	27 (1535)
Heat rejection to coolant kW (BTU/min)		
Prime Power	107 (6085)	112 (6369)
Max Standby Power	129 (7336)	103 (5835)
Fan power consumption, kW (hp)	9.2 (13)	15.8 (21)

Standard equipment

Engine

- Automatic belt tensioner
- Lift eyelets

Flywheel

- Flywheel housing with conn. acc. to SAE 2
- Flywheel 10" and 11.5" disc
- Vibration damper

Engine suspension

- Fixed integrated radiator front engine suspension

Lubrication system

- Oil dipstick
- Full-flow oil filter of cartridge type
- Oil cooler, side mounted

Fuel system

- Common rail
- Fuel filters of cartridge type
- Pre-filter with water separator

Intake and exhaust system

- Two-stage air filter with cyclon
- Connecting flange for exhaust pipe
- Turbo charger, low left side

Cooling system

- Tropical radiator incl intercooler
- Belt driven coolant pump
- Fan hub
- Pusher fan
- Fan guard
- Belt guard

Control system

- Engine Management System (EMS) with CAN-bus interface SAE J1939 and stand alone interface

Alternator

- Alternator 80A / 24 V

Starting system

- Starter motor, 5.0kW, 24 V
- Connection facility for extra starter motor

Instruments and senders

- Temp.- and oil pressure for automatic stop/alarm

Engine Packing

- Plastic wrapping

- ¹⁾ must be ordered, see order specification
- optional equipment or not applicable
- included in standard specification

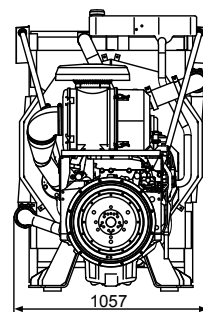
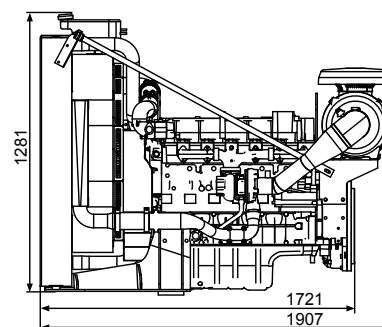

Note! Not all models, standard equipment and accessories are available in all countries. All specifications are subject to change without notice. The engine illustrated may not be entirely identical to production standard engines.

Power Standards

The engine performance corresponds to ISO 3046, BS 5514 and DIN 6271. The technical data applies to an engine without cooling fan and operating on a fuel with calorific value of 42.7 MJ/kg (18360 BTU/lb) and a density of 0.84 kg/liter (7.01 lb/US gal), also where this involves a deviation from the standards. Power output guaranteed within 0 to +2% at rated ambient conditions at delivery. Ratings are based on ISO 8528.

Engine speed governing in accordance with ISO 3046/IV, class A1 and ISO 8528-5 class G3

Exhaust emissions

The engine complies with Tier 2 and TA-luft exhaust emission regulations.

Rating Guidelines

PRIME POWER rating corresponds to ISO Standard Power for continuous operation. It is applicable for supplying electrical power at variable load for an unlimited number of hours instead of commercially purchased power. A10 % overload capability for governing purpose is available for this rating.

MAXIMUM STANDBY POWER rating corresponds to ISO Standard Fuel Stop Power. It is applicable for supplying standby electrical power at variable load in areas with well established electrical networks in the event of normal utility power failure. No overload capability is available for this rating. 1 hp = 1 kW x 1.36

Information

For more technical data and information, please look in the Generating Set Engines Sales Guide.

VOLVO PENTA

AB Volvo Penta
SE-405 08 Göteborg, Sweden
www.volvopenta.com