

VOLVO PENTA INDUSTRIAL DIESEL

TAD620VE

155 kW (211 hp) crankshaft power acc. to ISO 3046

The TAD620VE is a powerful, reliable and economical Versatile Diesel Engine.

Durability & low noise

Designed for easiest, fastest and most economical installation. Well-balanced to produce smooth and vibration-free operation with low noise level. To maintain a controlled working temperature in cylinders and combustion chambers, the engine is equipped with piston cooling.

Low exhaust emissions

The state of the art, high-tech injection and charging system with low internal losses contributes to excellent combustion and low fuel consumption. The TAD620VE complies with EU Stage 2, EPA/CARB Tier 2 exhaust emission regulations.

Easy service & maintenance

Modern injection system, integrated oil cooler and all service points located on one side provides best possible access in an installation. Replaceable valve guides and valve seats gives lower service and repair costs for the customer. A low maintenance poly-V belt is standard. Quality Volvo Penta support is available in more than 100 countries all over the world.

Technical description:

Engine and block

- Optimized cast iron cylinder block with optimum distribution of forces
- Piston cooling for low piston temperature and reduced ring temperature
- Drop forged steel connecting rods
- Crankshaft hardened bearing surfaces and fillets for moderate load on main and big-end bearings
- Keystone top compression rings for long service life
- Replaceable valve guides and valve seats
- Three PTO positions at flywheel end
- Automatic belt tensioner
- Lift eyelets
- Flywheel housing with connection acc to SAE 2
- Flywheel for flexible coupling and friction clutch
- Transport brackets
- Pulley for AC compressor

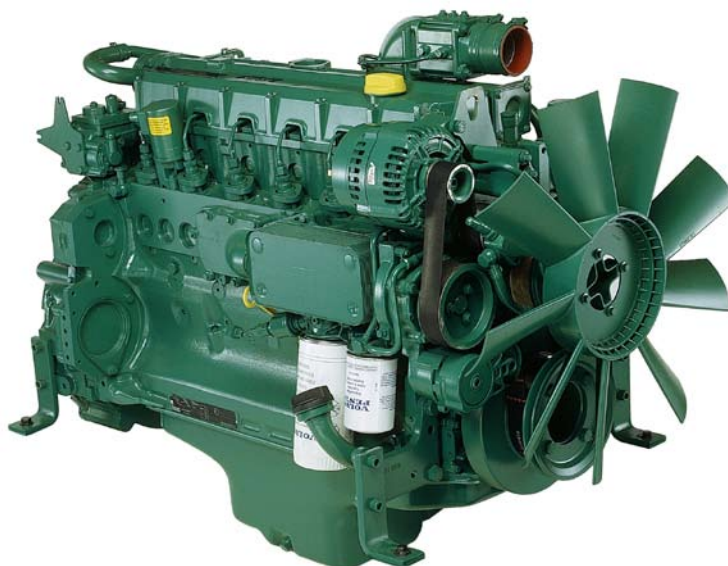

Features

- Compact design
- High power to weight ratio
- Emission compliant, EU Stage 2, EPA/CARB Tier 2
- Noise optimized engine design
- A wide selection of optional equipment and power settings
- Mechanical or electronic (EDC4) governing with CAN-bus communication

Lubrication system

- Full flow disposable spin-on oil filter, for extra high filtration
- Rotary displacement oil pump driven by the crankshaft
- Deep centre oil sump, 30° inclination
- Oil filler on valve cover
- Oil dipstick, right side, front
- Integrated full flow oil cooler, side-mounted

Fuel system

- Six hole fuel injection nozzles
- Direct injection unit pumps
- Mechanical or electronic governor with smoke limiter function.
- Washable fuel prefilter with water separator
- Belt driven rotary low-pressure fuel pump
- Fine fuel filter of disposable type
- Stop solenoid, electrically operated, E.T.R 24V

Intake and exhaust system

- Connection flange for exhaust line
- Turbo charger, centre low with exhaust flange

- Closed crankcase ventilation
- Heater flange in charge air inlet (without power relay)

Cooling system

- Belt driven, maintenance-free coolant pump with high degree of efficiency
- Efficient cooling with accurate coolant control through a water distribution duct in the cylinder block.
- Reliable sleeve thermostat with minimum pressure drop
- Cooling water pipe, inlet and outlet
- Fan hub
- Fan at separate bracket 290mm above crankshaft
- Suction type fan Ø600mm

Electrical system

- 24V electrical system
- Alternator 1x55A / 24V, high right side
- Starter motor, Melco, 5.5kW / 24V, single pole
- Engine wiring

**VOLVO
PENTA**

TAD620VE

Optional equipment

Engine

- Intermittent and Continuous power settings Tier 2 or EU stage 2 compliance
- SAE 3 flywheel housing
- Flywheel for clutch SAE 8"/10" and 11 1/2"
- Flywheel for Clark, ZF, and Allison transmissions

Lubrication system

- Deep front oil sump
- Oil dipstick in front, or rear
- Remote oil filter
- Oil filling on top and/or crankcase

Fuel system

- Fuel prefilter, heavy duty
- Hand pump

Intake and exhaust system

- Low or high turbo-charger
- Exhaust to front or rear
- Electric or mechanical air restriction indicator, 50mbar

Cooling system

- Fan at separate bracket 220 to 390mm above crankshaft
- Fan on coolant pump
- Fan on crankshaft
- Fan ratio 1:0,9 - 1:1,2
- Suction or pusher type fans Ø470 to 700mm
- 2 fixed fan hubs, and 2 viscous type hubs.

Control system

- 12V/24V electrical stop, energized to run or to stop
- VDO-E Gas
- ECU with high altitude sensor

Electrical system

- Alternator, 28V / 55-80A high right or low left
- Alternator, 14V / 95A high right or low left
- Starter motor, 24V / 5,5W
- Starter motor, 12V / 3,1kW
- Speed sender, hour meter, oil pressure sender and switch
- Extension cable 2.5m or 5m, engine to ECU

Miscellaneous

- Driving parts for hydr. pump on PTO A, B or C
- Hydr. pump on PTO B, 16cm³
- Coolant preheater
- Air compressor 150cm³ or 300cm³

Technical Data

Engine designation	TAD620VE
IFN Power at 2500rpm, kW (hp)	155 (211)
ICFN Power at 2500 rpm, kW (hp)	140 (190)
Torque at 1500rpm, Nm (lbf ft)	700 (517)
Displacement, l (in ³)	5.7 (347.8)
Number of cylinders	6
Bore/stroke, mm (in.)	98/126 (3.86/4.96)
Compression ratio	18.4:1
Dry weight, kg (lb)	570 (1270)

The engine performance corresponds to ISO 3046, BS 5514 and DIN 6271. The technical data applies to an engine without cooling fan and operating on a fuel with calorific value of 42.7 MJ/kg (18360 BTU/lb) and a density of 0.84 kg/litre (7.01 lb/US gal, 8.42 lb/Imp gal), also where this involves a deviation from the standards.

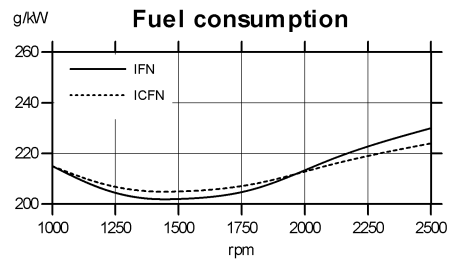
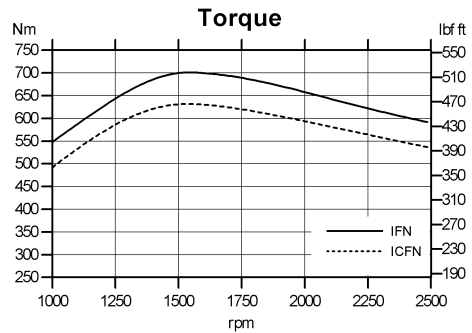
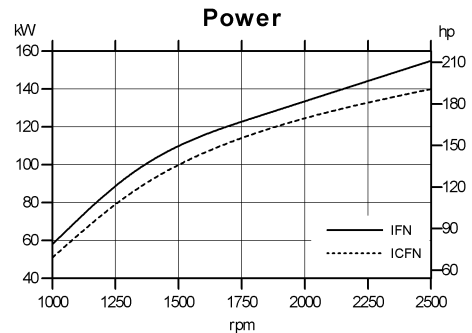

Dimensions TAD620VE

Not for installation

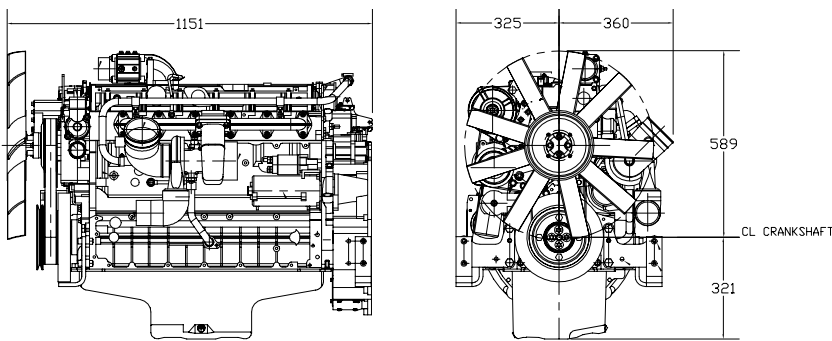

Note! Not all models, standard equipment and accessories are available in all countries. All specifications are subject to change without notice. The engine illustrated may not be entirely identical to production standard engines.

Power Standards

The engine performance corresponds to ISO 3046, BS 5514 and DIN 6271. The technical data applies to an engine without cooling fan and operating on a fuel with calorific value of 42.7 MJ/kg (18360 BTU/lb) and a density of 0.84 kg/litre (7.01 lb/US gal, 8.42 lb/Imp gal), also where this involves a deviation from the standards.

Rating Guideline

IFN Power rating corresponds to ISO Overload Power. It is intended for applications where intermittent power is utilized less than 1 hour within any period of 12 hours of continuous operation. The average load factor must not exceed the continuous rating.

ICFN Power rating corresponds to ISO Standard Power for continuous operation. It is intended for constant load applications with uninterrupted service at full load for extended periods of time.

Derating

The engine may be operated up to 1000 m altitude and 40°C ambient air temperature without derating. For operation at higher altitudes and temperatures the power should be derated according to the following factors:

Altitude derating factor < 3000 m	4 % / 500 m
Altitude derating factor > 3000 m	6 % / 500 m
Ambient temperature derating factor	2 % / 5 °C
Humidity	No derating

VOLVO PENTA

AB Volvo Penta
SE-405 08 Göteborg, Sweden
www.volvopenta.com