

VOLVO PENTA INDUSTRIAL DIESEL

TAD951VE

224 kW (305 hp) crankshaft power acc. to ISO 3046

The TAD951VE is a powerful, reliable and economical Industrial Diesel Engine built on the dependable Volvo in-line six design.

Durability & low noise

Designed for the easiest, fastest and most economical Installation. Well-balanced to produce smooth and vibration-free operation with low noise level, featured with high torque.

To maintain a controlled working temperature in cylinders and combustion chambers, the engine is equipped with piston cooling. The engine is also fitted with replaceable cylinder liners and valve seats/guides to ensure maximum durability and service life of the engine.

Operational economy and Low exhaust emission

The state of the art, high-tech injection and air charging system with low internal losses contributes to excellent combustion and low fuel consumption.

The TAD951VE complies with EPA/CARB Tier 3 and EU stage III exhaust emission regulations. These regulations are met by using V-ACT™ (Volvo Advanced Combustion technology).

V-ACT includes a flexible high pressure fuel injection system, an air management system including an internal exhaust gas recirculation device and an enhanced electronic controller.

Easy service & maintenance

Easily accessible service and maintenance points contribute to the ease of service of the engine.

Technical description:

Engine and block

- Optimized cast iron cylinder block with optimum distribution of forces without the block being unnecessary heavy.
- Wet, replaceable cylinder liners
- Piston cooling for low thermal load on pistons and reduced ring temperature
- Tapered connecting rods to reduce risk of piston cracking
- Crankshaft induction hardened bearing surfaces and fillets with seven main bearings for moderate load on main and big-end bearings
- Nitrocarburized transmission gears for heavy duty operation
- Keystone top compression rings for long service life
- Viscous type crankshaft vibration damper



- Replaceable valve guides and valve seats
- Over head camshaft and four valves per cylinder equipped with camshaft damper to reduce noise and vibrations.

Lubrication system

- Full flow oil cooler
- Full flow disposable spin-on oil filters, for extra high filtration
- The lubricating oil level can be measured during operation (Standard dipstick only)
- Gear type lubricating oil pump, gear driven by the transmission
- Oil level sensor at startup

Fuel system

- Non-return fuel valve
- Electronic Unit Injectors
- Fuel pre-filter with water separator and water-in-fuel indicator / alarm
- Gear driven low-pressure fuel pump
- Fuel pressure switch
- Self de-aerating system. When replacing filters all fuel stays in the engine.

Turbo charger

- Efficient and reliable turbo charger
- Extra oil filter for the turbo charger

Cooling system

- Air to air intercooler
- Belt driven, maintenance-free coolant pump

- with high degree of efficiency
- Coolant filter as standard
- Fan hub
- Fan & belt guard
- Efficient cooling with accurate coolant control through a water distribution duct in the cylinder block. Reliable sleeve thermostat with minimum pressure drop
- Tropical radiator
- Radiator guard
- Fan, suction or thrust type

Electrical system

- Engine Management System 2 (EMS 2), an electronically controlled processing system which optimizes engine performance. It also includes advanced facilities for diagnostics and fault tracing
- The instruments and controls connects to the engine via the CAN SAE J1939 interface, either through the Control Interface Unit (CIU) or the Digital Control Unit (DCU).
- Sensors for oil pressure, oil temp, boost pressure, boost temp, coolant temp, fuel temp, water in fuel, fuel pressure and two speed sensors. Crankcase pressure, piston cooling pressure, oil level and air filter pressure droop sensors
- Alternator 80A / 28V
- Starter motor

**VOLVO
PENTA**

TAD951VE

Technical Data

General

Engine designation	TAD951VE
No. of cylinders and configuration	in-line 6
Method of operation	4-stroke
Bore, mm (in.)	120 (4.72)
Stroke, mm (in.)	138 (5.43)
Displacement, l (in ³)	9.36 (571)
Compression ratio	20.2:1
Dry weight, kg (lb)	1015 (2238)
Wet weight, kg (lb)	1065 (2348)

Performance

IFN Power, without fan, at 2100 rpm, kW (hp)	224 (305)
Power, with fan Ø890mm, at 2100 rpm, kW (hp)	205 (279)
Torque at 1200 rpm, Nm (lbf ft)	1703 (1256)

Lubrication system

Oil system capacity incl filters, liter (US gal)	35 (9.25)
--	-----------

For details see Technical data

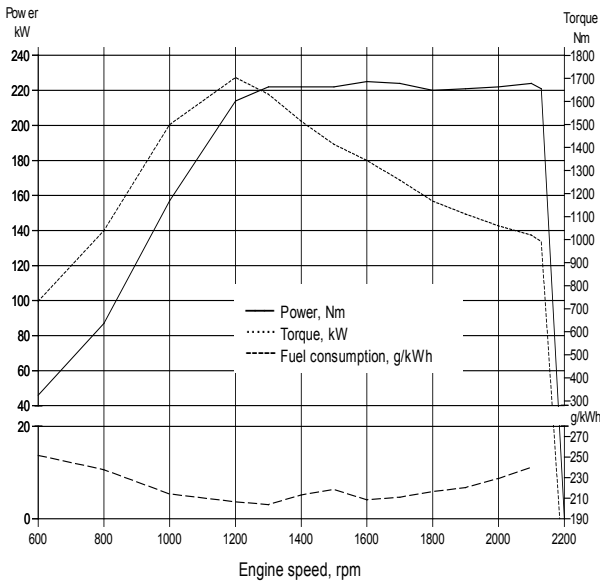

Dimensions TAD951VE

Not for installation

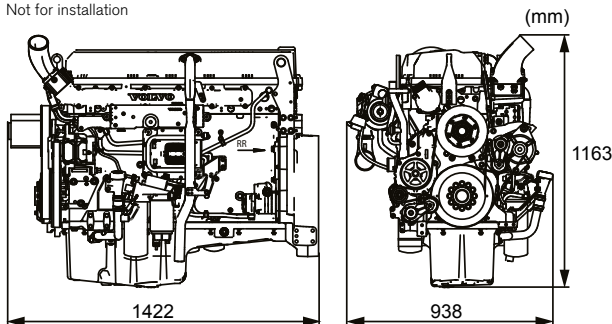

Note! Not all models, standard equipment and accessories are available in all countries. All specifications are subject to change without notice. The engine illustrated may not be entirely identical to production standard engines.

Power Standards

The engine performance corresponds to ISO 3046, BS 5514 and DIN 6271. The technical data applies to an engine without cooling fan and operating on a fuel with calorific value of 42.7 MJ/kg (18360 BTU/lb) and a density of 0.84 kg/litre (7.01 lb/US gal, 8.42 lb/Imp gal), also where this involves a deviation from the standards.

Rating Guideline

IFN Power rating corresponds to ISO Overload Power. It is intended for applications where intermittent power is utilized less than 1 hour within any period of 12 hours of continuous operation. The average load factor must not exceed the continuous rating. ICFN Power rating corresponds to ISO Standard Power for con-

tinuous operation. It is intended for constant load applications with uninterrupted service at full load for extended periods of time. The average load factor must not exceed 70% of the continuous rating when operating at continuous speed and load.

Derating

The engine will operate up to 1000 m altitude and 40°C without derating. For operation at higher altitudes the power will be derated according to the following factors, see technical data.

Standard and optional equipment

Engine

- Automatic belt tensioner
- Lift eyelets
- Flywheel housing with conn. acc. to SAE 1
- Flywheel for 14" flex. plate and flexible coupling
- Flywheel for ZF and DANA

Vibration dampers

Engine suspension

- Fixed front suspension

- Fixed rear suspension

Lubrication system

- Oil dipstick
- Oil dipstick, flexible
- Full-flow oil filter of spin-on type
- By-pass oil filter of spin-on type
- Remote oil filter of spin-on type
- Oil cooler, side mounted
- Low noise oil sump

Fuel system

- Fuel filters of disposable type
- Electronic unit injectors
- Pre-filter with water separator and water-in-fuel indicator/alarm

Intake and exhaust system

- Air filter with replaceable paper insert
- Connecting flange for exhaust pipe
- Exhaust flange with v-clamp
- Turbo charger, low right side
- Crankcase ventilation, open
- Crankcase ventilation with oil trap

Cooling system

- Tropical radiator incl. intercooler
- Belt driven coolant pump
- Fan hub
- Suction fan, 750 mm, with fan ring
- Suction fan, 890 mm
- Thrust fan, 890 mm
- Fan guard
- Belt guard

Control system

- Engine Management System 2 (EMS 2) with CAN-bus interface SAE J1939
- CIU, Control Interface Unit
- DCU, Display Control Unit

Alternator

- Alternator 80A / 28V
- Alternator 110A / 28V
- Alternator 140A / 28V

Starting system

- Starter motor, 5.5kW, 24V
- Connection facility for extra starter motor
- Air pre-heater

Instruments and senders

- Temp. and oil pressure for automatic stop/alarm

Other equipment

- Air compressor, 1 cylinder
- Air compressor, 2 cylinders
- AC compressor

Engine packing

- Plastic wrapping

- optional equipment or not applicable,
- included in standard specification

VOLVO PENTA

AB Volvo Penta
SE-405 08 Göteborg, Sweden
www.volvopenta.com