

VOLVO PENTA INBOARD DIESEL

D12-675

496 kW (675 hp) crankshaft power acc. to ISO 8665

Excellent Performance and Cruising Range

The D12-675 marine diesel engine is specially designed and developed for installations in fast planing craft featuring the latest advanced diesel technology.

Excellent performance is assured with a rich torque curve matched to the high power output for quick acceleration and high top speed.



World-class performance

Low fuel consumption for long cruising range and low emission levels is assured with:

- Electronic Unit Injectors
- 4-valve technology
- Electronically controlled injection timing
- High pressure 8-hole injector nozzles
- Electronic governing - EMS

This technology combined optimizes engine performance and efficiency, ensures efficient combustion by injecting the right quantity of fuel at the right time, which minimizes quantity of unburned fuel, reducing fuel consumption and exhaust emission levels. The Volvo Penta D12-675 fuel system is designed to give full output regardless of fuel temperature.

Reliability and high quality

The D12-675 is a further development of the well-proven Volvo Penta D12 in-line six concept with robust block design, ladder frame and a one-piece cylinder head with overhead camshaft and 4-valve technology. This contributes to smooth running, high reliability and long-term durability.

The D12-675 is built in the world's most highly automated diesel engine factory line with a robotic machining line with computer controlled audit checks, which ensures the highest quality level.

EVC/EC - Plug and go

EVC Electronic Vessel Control is the latest development in engine control and instrumentation for Volvo Penta marine engines. It offers a higher level of integration in your boat: electronic shift and throttle for smooth and safe control, a complete range of easy to read data link gauges, an EVC System

Display (option) and much more, everything in just one CAN cable.

EVC makes boating easier and safer with twin engine synchronization and new software functions such as Volvo Penta Low Speed/trolling (option), which significantly reduces boat speed at idle to simplify maneuvering in tight quarters.

EVC is scalable from one station up to four, from a classic dashboard up to an advanced driver information system. EVC works closely together with the engine management system offering you constant power output regardless of fuel temperature (5- 55°C / 41-131°F). The system is built on the latest automotive technology with waterproof connectors, so it's just plug and go.

As an option the engine can be equipped with a safety shutdown unit (SDU) with exclusive shutdown senders with full broken wire detection and a power module for automatic switch-over to backup power supply (PM).

Easy installation and service

The D12-675 together with EVC gives a time-saving and reliable installation, as it is a complete delivered compact and tailor-made propulsion system from one single supplier.

The EVC system features a self-diagnostic facility. Easily accessible service and maintenance points contribute to the ease of service of the engine.

Meeting new emission standards

The high pressure unit injector system in combination with electronics and an advanced combustion system are setting new standards in minimizing noxious emissions and particulates. The engine complies with IMO and River Rhine (CCNR) Stage 1.

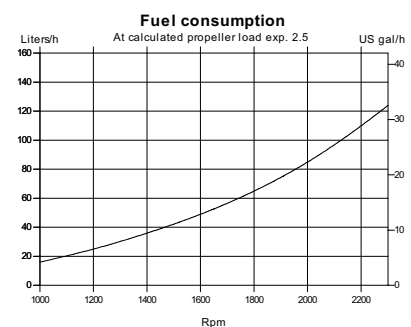
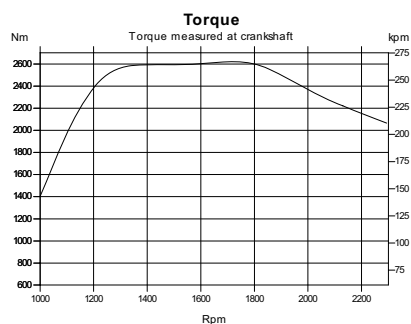
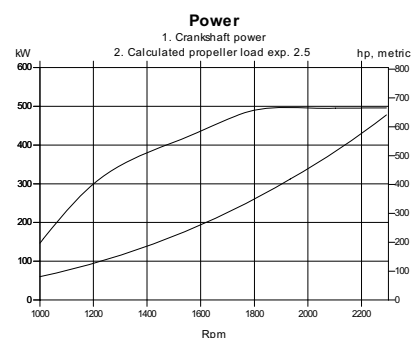

**VOLVO
PENTA**

D12-675

Technical description:

Engine and block

- Cylinder block and cylinder head made of cast-iron
- One-piece cylinder head
- Ladder frame fitted to engine block
- Replaceable wet cylinder liners and valve seats/guides
- Drop forged crankshaft with induction hardened bearing surfaces and fillets with seven main bearings
- Four valve per cylinder layout with overhead camshaft
- Each cylinder features cross-flow inlet and exhaust ducts
- Gallery oil-cooled cast aluminum alloy pistons with three piston rings

Engine mounting

- Flexible engine mounting (option)

Lubrication system

- Integrated oil cooler in cylinder block
- Twin full flow oil filter of spin-on type and by-pass filter

Fuel system

- Electronic Unit Injectors, one per cylinder, vertically positioned at the center in between the four valves
- 6-hole high pressure injector nozzles
- Gear-driven fuel pump, driven by timing gear
- Electronically controlled central processing system (EMS-2 – Engine Management System)
- Electronically controlled injection timing
- Single fine fuel filter of spin-on type, with water separator

Turbocharger

- Freshwater-cooled turbo charger

Air inlet and exhaust system

- Air filter with replaceable inserts
- Wet exhaust elbow (option)

Cooling system

- Freshwater-cooled charge air cooler
- Gear-driven coolant pumps
- Tubular heat exchanger with priority valve

Electrical system

- 24V electrical system, 24V/60A alternator

Instruments/controls (option)

- Complete instrumentation including key switch and interlocked alarm
- EVC monitoring panels for single or twin installations
- Electronic remote control for throttle and shift
- Plug-in connections

Reverse gear

- ZF325A-EB, electronically shifted. Low speed/trolling as option.

Optional equipment

- Closed crankcase ventilation (CCV)
- For further information regarding optional equipment, contact your Volvo Penta representative.

Not all models, standard equipment and accessories are available in all countries. All specifications are subject to change without notice.

The engine illustrated may not be entirely identical to production standard engines.

Technical Data

Engine designation	D12D-C MP
No. of cylinders and configuration.....	in-line 6
Method of operation	4-stroke, direct-injected, turbocharged diesel engine with aftercooler
Bore/stroke, mm (in.).....	131/150 (5.16/5.91)
Displacement, l (in ³).....	12.1 (740.2)
Compression ratio.....	16.5:1
Dry weight bobtail, kg (lb)	1400 (3086)
Dry weight with reverse gear ZF325A-EB, kg (lb)..	1570 (3461)
Crankshaft power, kW (hp) @ 2300 rpm	496 (675)
Max. torque, Nm (lb.ft) @ 1400 rpm.....	2600 (1919)
Recommended fuel to conform to.....	ASTM-D975 1-D & 2-D, EN 590 or JIS KK 2204
Specific fuel consumption, g/kWh (lb/hph) @ 2300 rpm	219 (0.355)

Technical data according to ISO 3046 Fuel Stop Power and ISO 8665. With fuel having an LHV of 42700 kJ/kg and density of 840 g/liter at 15°C (60°F). Merchant fuel may differ from this specification which will influence engine power output and fuel consumption.

Rating: 4

The engine complies with IMO and River Rhine (CCNR) Stage 1.

Dimensions D12-675 with ZF325A-EB

Not for installation

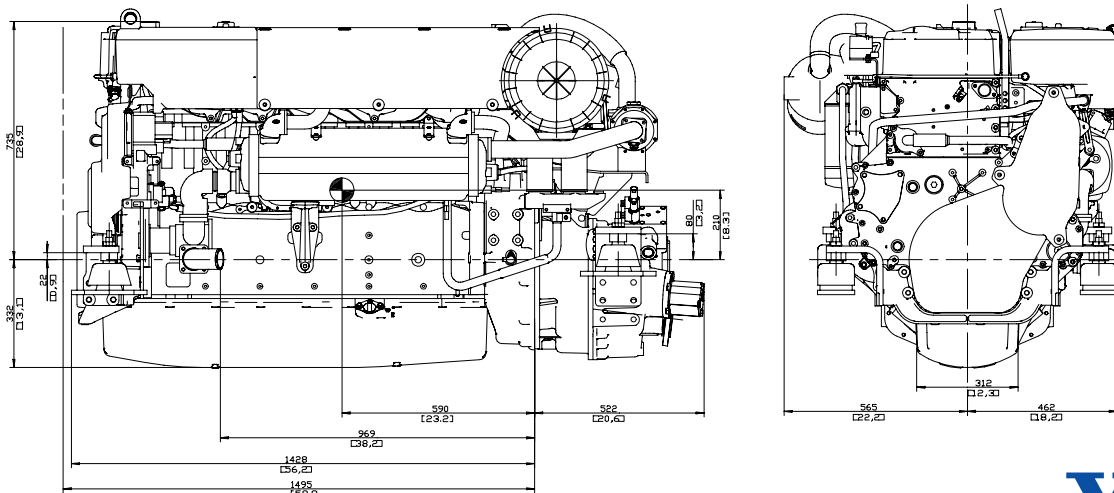

VOLVO PENTA

AB Volvo Penta
SE-405 08 Göteborg, Sweden
www.volvopenta.com