

VOLVO PENTA INBOARD DIESEL

D16 MH

NEW!

368–552 kW (501–751 hp) crankshaft power acc. to ISO 3046, rating 1–2

Powerful and Clean

The new D16 in-line 6 diesel is specially designed and developed for installations in heavy duty commercial displacement craft, featuring the latest design in modern diesel technology. The engine features a robust block with ladder frame, high pressure unit injector system, 4 valves per cylinder, “twin entry” turbo and charge air cooler. The heat exchanger is designed for reduced charge-air-cooling temperature, which in combination with the injection system, and the Engine Management System (EMS-2) further improve performance and drivability, meeting future stringent emission requirements. This results in a very smooth running engine with world-class performance, combined with low fuel consumption and low emissions.



World-class performance

State-of-the-art engine technology featuring the world's most efficient charge air cooler, high pressure unit injector system, in combination with twin entry turbo charger, all of which ensure high power, low fuel consumption, and outstanding torque during load acceptance, with virtually no sign of smoke. All controlled by the Volvo developed electronic management system.

Durability and high quality

The D16 MH is a further development of the well-proven Volvo Penta D12 in-line six concept with robust block design, rear-end transmission, ladder frame and a one-piece cylinder head with overhead camshaft and 4-valve technology. This contributes to excellent operating economy, high reliability and long-term durability.

The D16 MH is built in the world's most highly automated diesel engine factory line with robotic machining and computer controlled audit checks, which ensures the highest quality level.

EVC/EC - Plug and go

EVC Electronic Vessel Control is the latest development in engine control and instrumentation for Volvo Penta marine engines. It offers a higher level of integration in your boat: electronic shift and throttle for smooth and safe control, a complete range of easy to read data link gauges, an EVC system display (option) and much more, everything in just one CAN cable.

EVC makes boating easier and safer, offering twin engine synchronization and the new software function trip computer. EVC is scalable from one station up to four, from a classic dashboard up to an advanced driver information system. EVC works closely together with the engine management system, offering you constant power output regardless of fuel temperature (5–55°C/41–131°F). The system is built on the latest automotive technology with waterproof connectors, so it's just plug and go.

As an option the EVC system is fully classifiable with a safety shutdown unit (SDU) with exclusive shutdown senders with full broken wire detection and a power module for automatic switch-over to backup power supply (PM).

Ease of service and maintenance

The EVC system features a self-diagnostic facility, which indicates on the instrument panel if a failure should occur. The engine has a compact and clean design, easy to service and maintain.

Meeting new emission standards

The high-pressure unit injector system in combination with electronics and an advanced combustion system are setting new standards in minimizing noxious emissions and particulates. The engine complies with IMO, River Rhine (CCNR) Stage 2 and US EPA Tier 2 exhaust emission legislations.

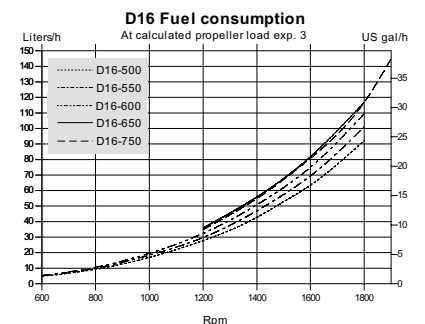
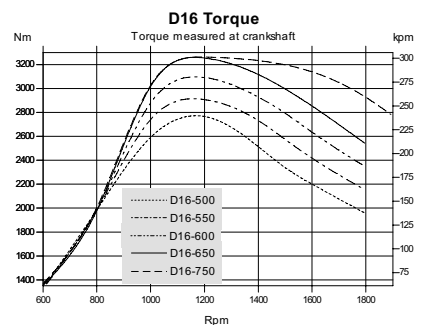
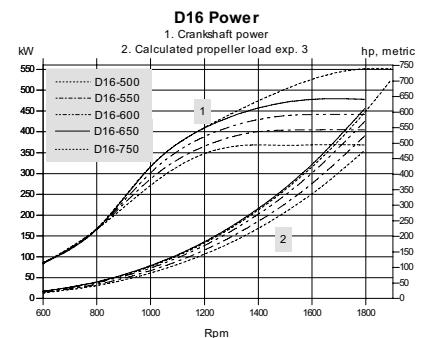

**VOLVO
PENTA**

D16 MH

Technical description:

Engine and block

- Cylinder block and cylinder head made of cast-iron
- One-piece cast-iron cylinder head
- Ladder frame fitted to engine block
- Replaceable wet cylinder liners and valve seats/guides
- Drop forged crankshaft with induction hardened bearing surfaces and fillets with seven main bearings
- Four valve per cylinder layout with overhead camshaft
- Each cylinder features cross-flow inlet and exhaust ducts
- Gallery oil-cooled cast aluminum alloy pistons with three piston rings
- Rear-end transmission

Engine mounting

- Flexible engine mounting (option)

Lubrication system

- Integrated oil cooler in cylinder block
- Twin full flow oil filters and by-pass filters of spin-on type

Fuel system

- Electronic Unit Injectors, one per cylinder, vertically positioned at the center in between the four valves
- 5-hole high pressure injector nozzles
- Gear-driven fuel pump, driven by timing gear
- Electronically controlled central processing system (EMS – Engine Management System)
- Electronically controlled injection timing
- Single fine fuel filter of spin-on type, with water separator and water alarm

Air inlet and exhaust system

- Air filter with replaceable inserts
- Mid-positioned twin entry turbocharger and charge air cooler

Cooling system

- Freshwater-cooled charge air cooler
- Seawater-cooled tubular heat exchanger
- Coolant system prepared for hot water outlet
- Easily accessible seawater impeller pump in rear end

Electrical system

- 24V/80A alternator

Instruments/controls (option)

- MCC – Marine Control System
- Complete instrumentation including key switch and interlocked alarm
- EVC monitoring panels for single or twin installations
- Electronic remote control for throttle and shift
- Plug-in connections
- SDU shutdown unit for classified installations

Reverse gear

- MG5145A-E and MG5170DC-E, electrically shifted.

Optional equipment

Contact your Volvo Penta representative.

Not all models, standard equipment and accessories are available in all countries. All specifications are subject to change without notice.
The engine illustrated may not be entirely identical to production standard engines.

Technical Data

Engine designation	D16 MH				
No. of cylinders and configuration.....	in-line 6				
Method of operation	4-stroke, direct-injected, turbocharged diesel engine with charge air cooler				
Bore/stroke, mm (in.).....	144/165 (5.67/6.50)				
Displacement, l (in ³).....	16.12 (983.9)				
Compression ratio.....	17.5:1				
Dry weight bobtail, kg (lb)	1750 (3858)				
Dry weight with reverse gear					
MG5145SC-E, kg (lb)	2110 (4652)				
MG5170DC-E, kg (lb)	2610 (5754)				
Rating/rpm	R1/1800 rpm	R1/1800 rpm	R1/1800 rpm	R1/1800 rpm	R2/1900 rpm
Crankshaft power, kW (hp)	368 (501)	405 (551)	442 (601)	479 (651)	552 (751)
Max. torque, Nm (lb.ft) @ 1200 rpm.....	2766 (2040)	2907 (2144)	3092 (2280)	3265 (2408)	3267 (2410)
Specific fuel consumption,					
g/kWh (lb/hph) @ 1400 rpm	197 (0.320)	196 (0.317)	195 (0.316)	194 (0.313)	199 (0.322)
g/kWh (lb/hph) @ 1800 rpm	209 (0.339)	209 (0.338)	209 (0.339)	210 (0.341)	209 (0.339)
Recommended fuel to conform to.....	ASTM-D975 1-D & 2-D, EN 590 or JIS KK 2204				

Technical data according to ISO 3046 Fuel Stop Power and ISO 8665. Fuel with a lower calorific value of 42700 kJ/kg and density of 840 g/liter at 15°C (60°F). Merchant fuel may differ from this specification which will influence engine power output and fuel consumption.

Ratings R1 & R2, see explanation in Volvo Penta's Sales Guide.

The engine complies with IMO, River Rhine (CCNR) Stage 2 and US EPA Tier 2 exhaust emission legislations.

Dimensions D16 MH with MG5170DC-E

Not for installation

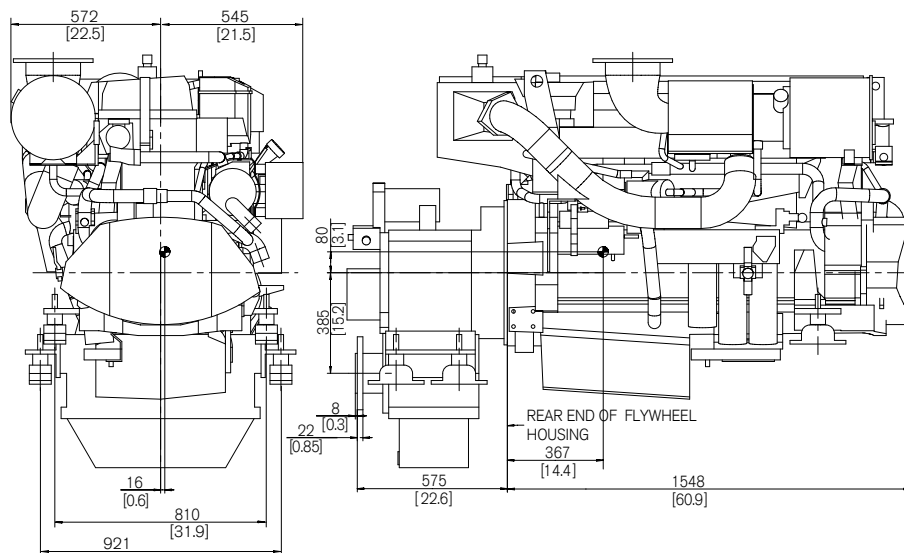

VOLVO PENTA

AB Volvo Penta
SE-405 08 Göteborg, Sweden
www.volvopenta.com