

6-cylinder, 4-stroke, direct-injected, turbocharged marine diesel engine with aftercooler – crankshaft power* 130–174 kW (177–234 hp)

* Power rating – see Technical Data

Reliable and powerful

The D7ATA is a highly reliable, type approved, marine diesel engine. Well-matched engine speed to rated power with excellent torque characteristics along with a variety of power take-off options makes it particularly well suited for displacement and semi-planing workboats in medium and heavy duty service.

Robust and silent

A rigid in-line cylinder block with generously dimensioned crankshaft bearings, together with watercooled exhaust manifold and turbo, are just some of the design features making this silent running and sturdy engine. The owner of a D7ATA not only benefits from many hours of trouble-free operation, but also enjoys improved onboard comfort.

Economical and service friendly

Price is not the only concern when investing in a new engine. As confirmed by marine professionals, it is the operational costs, such as cost for fuel, spare parts, service and maintenance, that makes the real difference in economy.

The D7ATA is equipped with unit pumps that control the fuel distribution for each cylinder. Six-hole high-pressure injection nozzles optimize the fuel-air mixture. This improved combustion results in high thermal efficiency, low fuel consumption, reduced exhaust emissions, faster response to load variations and ease in maintenance.

Easily accessible maintenance points and single side servicing contribute to the ease of servicing the engine. Liners of wet and replaceable type, inclined connecting rod caps and replaceable valve seats make even major maintenance possible to carry out on-board.

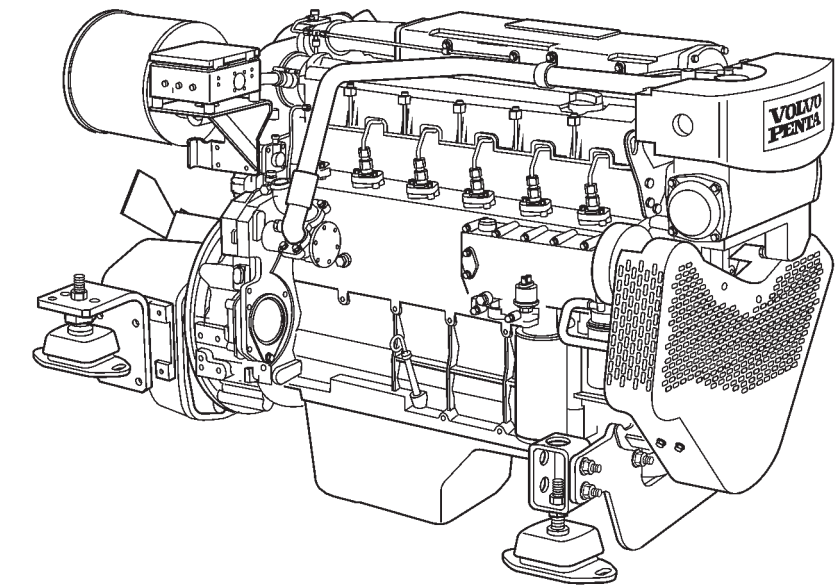

Safely supported

Volvo Penta has a well-established, well-trained, network of authorized service dealers in more than 100 countries throughout the world. These service centers offer Genuine Volvo Penta Parts as well as skilled service personnel to help you protect your investment.

Technical description:

Engine and block

- Cylinder block, head and flywheel housing made of cast iron
- Belt guard
- Combined 10" and 11.5" flywheel with SAE 2 housing
- Nitrocarburized transmission gears
- Press-hardened crankshaft
- Forged aluminum pistons
- Cylinder liners of wet type

Lubrication system

- Oil filler in valve cover
- Oil sump made of cast iron
- Manual oil drain pump
- Rotary lubrication oil pump
- Freshwater-cooled oil cooler
- Full flow oil filters of spin-on type
- Closed crankcase ventilation system

Fuel system

- Fuel feed pump
- Fine fuel filter of spin-on type
- Unit pumps
- Six-hole injectors
- Mechanical governor with smoke limiter
- Fuel stopping solenoid 24V

Cooling system

- 2-circuit keel cooling system with expansion tank
- Gear-driven seawater pump
- Belt-driven freshwater pump
- Freshwater-cooled turbocharger and exhaust manifold

Electrical system

- 2-pole 24V electrical system, 24V/55A alternator, 24V 4kW starter
- Senders and switches:
 - Tachometer
 - Lubrication oil pressure
 - Cooling-water temperature
 - Cooling-water level
- Rubber-suspended electrical terminal box with semi-automatic fuses and plug-in connection

D7A TA

Technical Data

Engine designation	D7A TA
No. of cylinders and configuration.....	in-line 6
Method of operation	4-stroke, direct-injected, turbocharged diesel engine with aftercooler
Bore, mm (in.).....	108 (4.25)
Stroke, mm (in.)	130 (5.12)
Displacement, l (in ³).....	7.15 (436)
Compression ratio.....	17.6:1
Dry weight, kg (lb).....	690 (1521)
Dry weight with reverse gear ZF280, kg (lb).....	760 (1676)
Crankshaft power,	
Rating 2, kW (hp) 2300 rpm	174 (237)
Rating 2, kW (hp) 1900 rpm	153 (208)
Rating 1, kW (hp) 2300 rpm	148 (201)
Rating 1, kW (hp) 1900 rpm	130 (177)
Max. torque,	
Rating 2, Nm (lbf.ft) 1500 rpm	809 (596)
Rating 2, Nm (lbf.ft) 1500 rpm	802 (592)
Rating 1, Nm (lbf.ft) 1500 rpm	688 (507)
Rating 1, Nm (lbf.ft) 1500 rpm	688 (507)
Recommended fuel to conform to.....	
ASTM-D975 1-D & 2-D, EN 590 or JIS KK 2204	
Specific fuel consumption,	
Rating 2, g/kWh (lb/hph) 2300 rpm	216 (0.350)
Rating 2, g/kWh (lb/hph) 1900 rpm	204 (0.330)
Rating 1, g/kWh (lb/hph) 2300 rpm	216 (0.350)
Rating 1, g/kWh (lb/hph) 1900 rpm	205 (0.332)

Fuel temperature 40°C (104°F)

Technical data according to ISO 3046 Fuel Stop Power and ISO 8665. With fuel having an LHV of 42700 kJ/kg and density of 840 g/liter at 15°C (60°F). Merchant fuel may differ from this specification which will influence engine power output and fuel consumption.

N.B. The product can also be used in an application with a higher rating than stated, e.g. R1 can be used for R2.

The engines are certified according to IMO and River Rhine (CCNR) Stage 1.

Optional equipment

Engine

- Flexible suspension for engine and reverse gear
- Combined 10"/11.5" flywheel with SAE 3 housing

Lubrication system

- Shallow oil sump
- Twin oil filters, for remote mounting

Fuel system

- Hand pump
- Jacketed fuel pipes
- Single or twin fuel/water separating pre filter
- Twin fuel filters, for remote mounting

Exhaust system

- Exhaust elbow, wet
- Exhaust elbow, dry, with integrated flexible compensator
- Silencer, dry

Cooling system

- Engine-mounted tubular heat exchanger with integrated expansion tank
- Seawater filter

Electrical system

- 1-pole 12V electrical system, 12V/95A alternator, 12V/3.1kW starter
- 24V/140A alternator
- Engine heater 230V/820W
- Senders:
 - Charge air pressure
 - Gearbox oil pressure
- Cable harness in different lengths
- Various instrument panels

Power transmission

- PTO crankshaft front end, type stub shaft
- Hydraulic pump for steering and other duties

Reverse gear

- ZF220
- ZF280

Contact your local Volvo Penta dealer for further information.

Not all models, standard equipment and accessories are available in all countries. All specifications are subject to change without notice.

The engine illustrated may not be entirely identical to production standard engines.

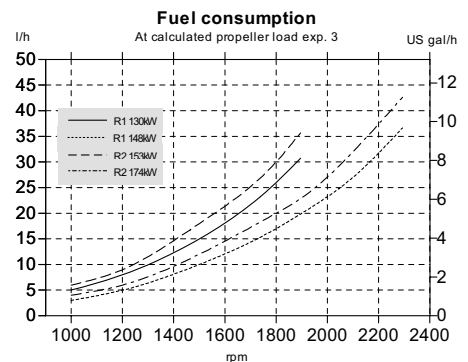
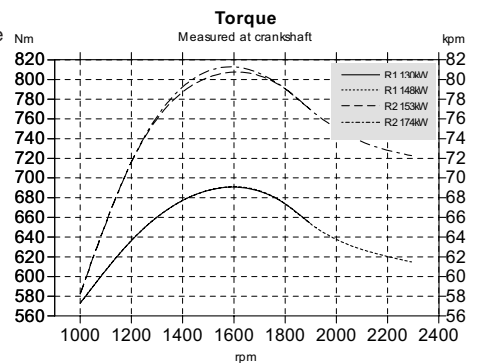
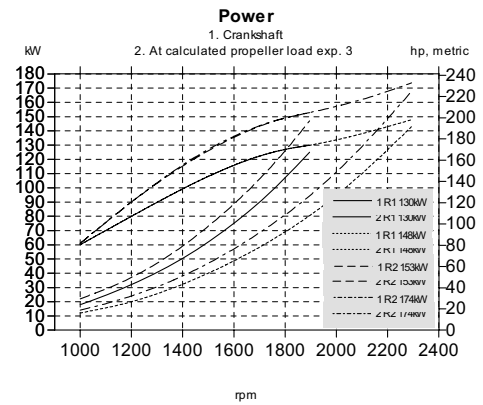

Dimensions D7A TA/ZF280 (mm)

Not for installation

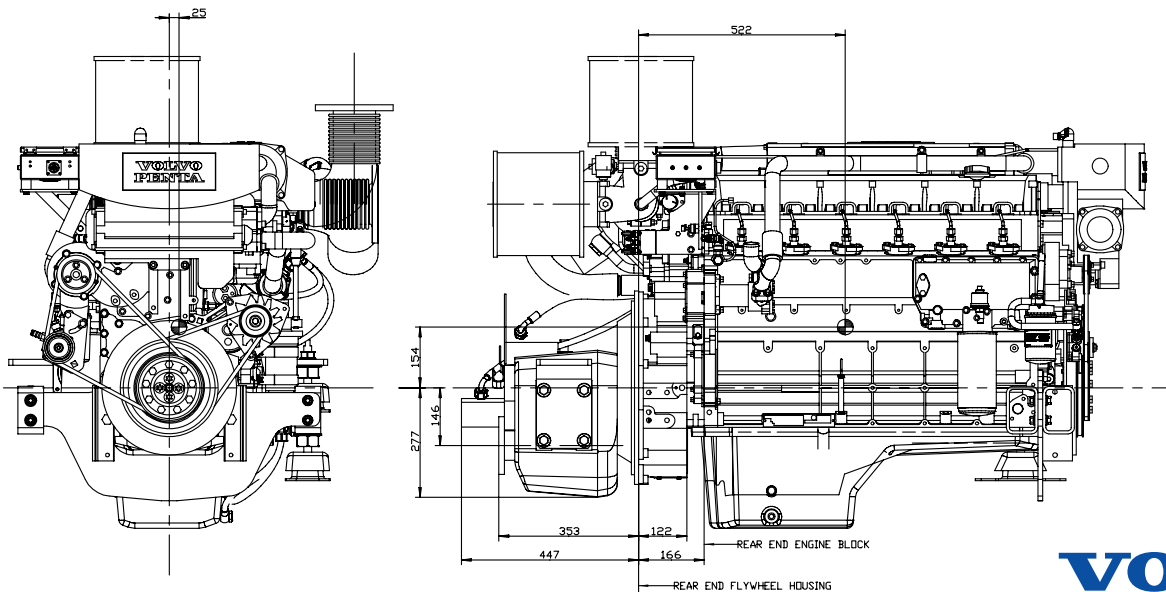

AB Volvo Penta
SE-405 08 Göteborg, Sweden
www.volvopenta.com