

VOLVO PENTA INBOARD DIESEL

D9-425/500

313–368 kW (425–500 hp) crankshaft power acc. to ISO 3046, rating 3–4

Performance out of the ordinary

The D9 in-line 6 diesel is developed from the latest design in modern diesel technology. The engine has a robust block with ladder frame, high pressure unit injector system, 4 valves per cylinder, “twin entry” turbo and aftercooler. Together with a large swept volume and the electronic engine management system, this results in a very smooth running engine with world-class performance, combined with low fuel consumption and low emissions.

World-class performance

The high pressure unit injector system, controlled by in-house developed electronic management, modern engine technology in combination with a large swept volume, and twin entry turbo charger ensure high power, low fuel consumption, and outstanding torque during acceleration, with virtually no sign of smoke. This matched with the engine’s high load carrying capability gives excellent driving characteristics.

Durability and high quality

The D9-425 and D9-500 are a further development of the well-proven Volvo Penta D12 in-line six concept with robust block design, rear-end transmission, ladder frame and a one-piece cylinder head with overhead camshaft and 4-valve technology. This contributes to excellent operating economy, high reliability and long-term durability.

The D9-425 and D9-500 are built in the world’s most highly automated diesel engine factory line with robotic machining and computer controlled audit checks, which ensures the highest quality level.

EVC/EC – Plug and go

EVC Electronic Vessel Control is the latest development in engine control and instrumentation for Volvo Penta marine engines. It offers a higher level of integration in your boat: electronic shift and throttle for smooth and safe control, a complete range of easy to read, data link gauges, an EVC system display (option)



and much more, everything in just one CAN cable.

EVC makes boating easier and safer, offering twin engine synchronization and new software functions such as Volvo Penta Low Speed/Trolling (option), which significantly reduces boat speed at idle to simplify maneuvering in tight quarters.

EVC is scalable from one station up to four, from a normal instrument panel up to an advanced driver information system. EVC works closely together with the engine management system offering you constant power output regardless of fuel temperature (5–55°C/41–131°F). The system is built on the latest marine technology with waterproof connectors, so it’s just plug and go. The EVC system is type approved.

Ease of service and maintenance

The EVC system features a self-diagnostic facility, which indicates at the instrument panel if a failure should occur. The engine has a compact and clean design, and with all fluid filters symmetrically positioned at the rear the engine is easy to service and maintain.

Meeting new emission standards

The advanced combustion system with high pressure unit injectors in combination with electronics are meeting the new legislations aiming to minimize noxious emissions and particulates. The engine complies with IMO, River Rhine (CCNR) Stage 1 and US EPA Tier 2.

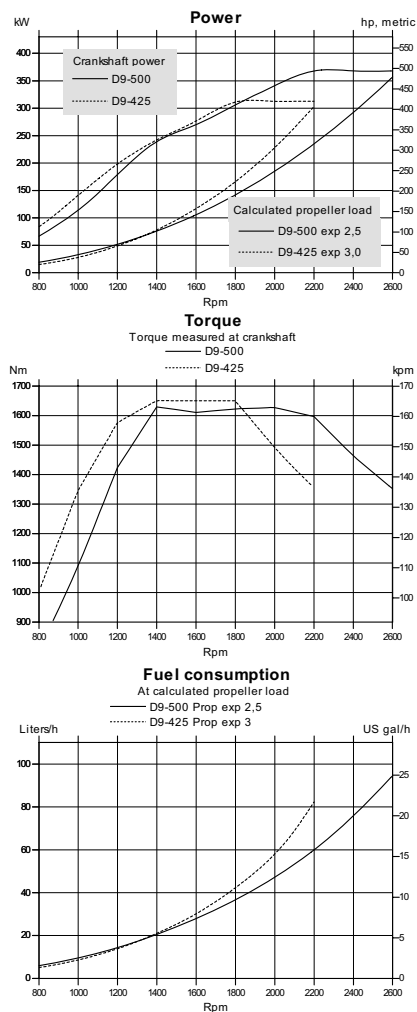

**VOLVO
PENTA**

D9-425/500

Technical description:

Engine and block

- Cylinder block and cylinder head made of cast-iron
- One-piece cast-iron cylinder head
- Ladder frame fitted to engine block
- Replaceable wet cylinder liners and valve seats/guides
- Drop forged crankshaft with induction hardened bearing surfaces and fillets with seven main bearings
- Four valve per cylinder layout with overhead camshaft
- Each cylinder features cross-flow inlet and exhaust ducts
- Gallery oil-cooled cast aluminum alloy pistons with three piston rings
- Rear-end transmission

Engine mounting

- Flexible engine mounting (option)

Lubrication system

- Integrated oil cooler in cylinder block
- Symmetrically positioned twin full flow oil filter of spin-on type and by-pass filter

Fuel system

- Electronic Unit Injectors, one per cylinder, vertically positioned at the center in between the four valves
- High pressure injector nozzles
- Gear-driven fuel pump, driven by timing gear
- Electronically controlled central processing system (EMS – Engine Management System)
- Electronically controlled injection timing
- Single fine fuel filter of spin-on type, with water separator and water alarm

Air inlet and exhaust system

- Air filter with replaceable inserts
- Mid-positioned twin entry turbocharger with aftercooler
- Wet exhaust elbow (option)

Cooling system

- Seawater-cooled tubular heat exchanger
- Coolant system prepared for hot water outlet
- Easily accessible seawater impeller pump in rear end

Electrical system

- 24V/80A alternator

Instruments/controls (option)

- Complete instrumentation including key switch and interlocked alarm
- EVC monitoring panels for single or twin installations
- Electronic remote control for throttle and shift
- Plug-in connectors

Reverse gear

- MG5075A-E/-IVE (R4), MG5065 (R4), ZF286A-E/IV-E and ZF305A-EB, electronically shifted. Low Speed/Trolling as option.

Optional equipment

Contact your Volvo Penta representative.

Not all models, standard equipment and accessories are available in all countries. All specifications are subject to change without notice.
The engine illustrated may not be entirely identical to production standard engines.

Technical Data

Engine designation	D9-425 (R3)	D9-500 (R4)
No. of cylinders and configuration	in-line 6	in-line 6
Method of operation	4-stroke, direct-injected, turbocharged diesel engine with aftercooler	
Bore/stroke, mm (in.).....	120/138 (4.72/5.43)	120/138 (4.72/5.43)
Displacement, l (in ³).....	9.4 (571)	9.4 (571)
Compression ratio	20.2:1	17.4:1
Dry weight bobtail, kg (lb).....	1075 (2370)	1075 (2370)
Dry weight with reverse gear		
ZF305A-EB, kg (lb).....		1205 (2657)
Crankshaft power, kW (hp) @ 2200 rpm	313 (425)	
Crankshaft power, kW (hp) @ 2600 rpm		368 (500)
Max. torque, Nm (lb.ft) @ 1400 rpm.....	1651 (1217)	1630 (1202)
Recommended fuel to conform to	ASTM-D975 1-D & 2-D, EN 590 or JIS KK 2204	
Specific fuel consumption,		
g/kWh (lb/hph) @ 2200 rpm.....	222 (0.36)	
g/kWh (lb/hph) @ 2600 rpm.....		217 (0.352)

Technical data according to ISO 3046 Fuel Stop Power and ISO 8665. With fuel having an LHV of 42700 kJ/kg and density of 840 g/liter at 15 °C (60 °F). Merchant fuel may differ from this specification which will influence engine power output and fuel consumption.

The engine complies with IMO, River Rhine (CCNR) Stage 1 and US EPA Tier 2.

Ratings R3 & R4, see explanation in Volvo Penta's Sales Guide.

Dimensions D9-425/500 with ZF305A-EB

Not for installation

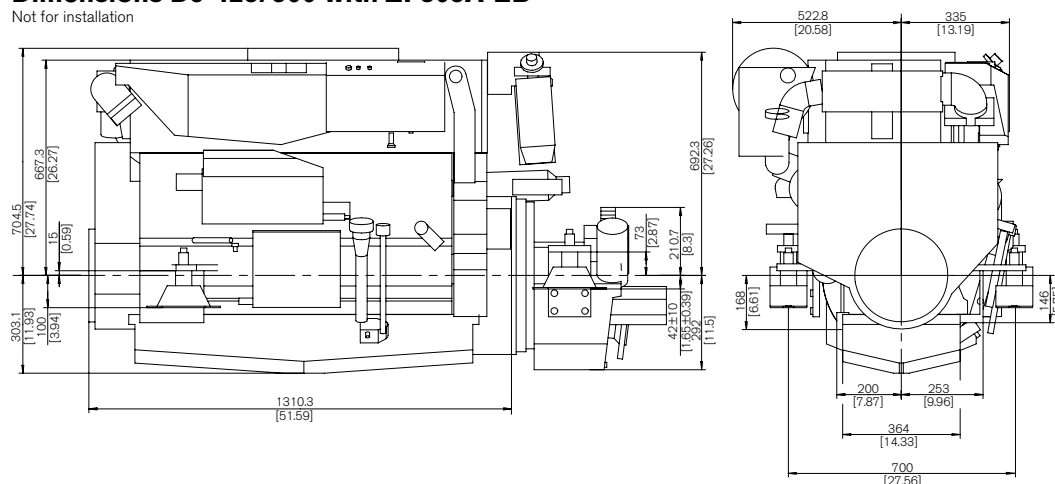

VOLVO PENTA

AB Volvo Penta
SE-405 08 Göteborg, Sweden
www.volvopenta.com