

VOLVO PENTA INBOARD DIESEL

D3-170, 200, 220

125-147-162 kW (170-200-220 hp) crankshaft power acc. to ISO 8665

PRELIMINARY

The new D3

Volvo Penta's new D3 has been developed using the latest available engine technology. It only has the name and number of cylinders in common with the first generation D3.

- Common rail system with piezo-electric injectors
- Equipped with Volvo Penta EVC-EC for electronic shift & throttle
- Lightweight and compact
- Quiet and comfortable



World-class performance

The 1800 bar common rail fuel injection system with piezo-electric injectors performing multiple injections per cycle gives an extraordinary performance. In combination with a Variable Geometry Turbocharger (VGT) this ensures outstanding acceleration, with no sign of smoke.

Robust, compact and lightweight

With cast-in grey iron cylinder liners, integrated freshwater pump, and a neatly designed marinization based on Volvo Penta's unique experience, the new D3 is a very robust engine. It is ultra-compact for its swept volume and fully symmetrical, making the package very easy to install.

Aluminum cylinder block and head gives the engine an extremely low weight for its power output.

The D3 is equipped with an engine cover that in addition to protecting the engine also gives it a modern and exclusive appearance.

Comfort

The D3 is equipped with the same type of successful engine mounts that were introduced for the D4/D6 engines. The multiple injection system in combination with the new type of engine mounts makes the engine amazingly quiet and comfortable at low speeds.

EVC-EC - Plug and go

EVC, Electronic Vessel Control, is the proven propulsion and boat management system that is used for the D3-D16 range of diesel engines. It offers a higher level of integration in your boat: electronic

shift and throttle for smooth and safe control, and a complete range of easy to read data link gauges and display options including the new 7" color display.

EVC makes boating easier and safer, offering twin engine synchronization and new software functions such as Volvo Penta Low Speed (option), which significantly reduces boat speed at idle to simplify maneuvering in tight quarters. It gives a base for additional functionalities such as Trip Computer, which is a good tool for optimizing cruising speed and trim settings for best fuel efficiency.

The EVC-EC is scalable from one driving station up to four, with easy plug-in installation. EVC works closely together with the engine management system offering you constant power output regardless of temperature and quality of the fuel.

A propulsion package fully matched, tested and supported by one company

Volvo Penta's hydraulically shifted reverse gear has been specially developed with a view to increasing the standard of comfort on board.

The combination of 8° down angle, large drop center and small dimensions provides for optimized installations. V-drives are also available.

In order to get full benefit of the EVC system the reverse gear is equipped with electric shifting valve.

Prepared for new emission standards

The new engine has outstandingly low emissions. In addition to meeting the existing emission requirements it is prepared to meet the stringent US EPA Tier 3 regulations that will take effect in 2012.

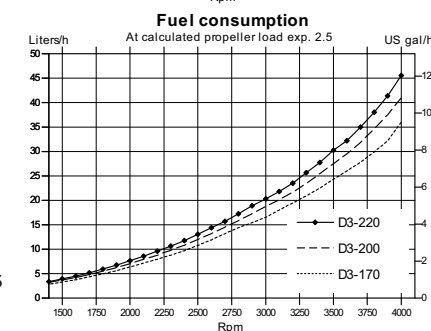
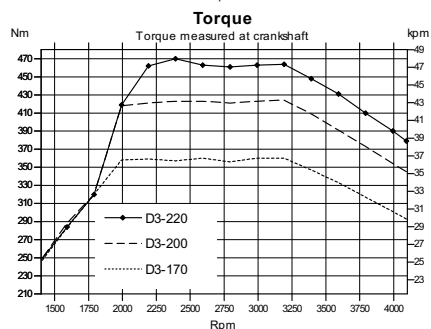
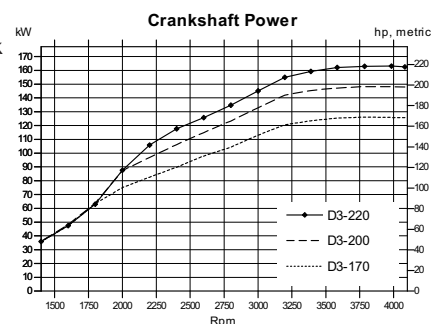

**VOLVO
PENTA**

D3-170,200,220

Technical description:

Engine block and head

- Cylinder block and head made of aluminum
- Cylinder block with integrated bed plate
- 4-valve technology with hydraulic lash adjusters
- Double overhead camshafts
- Oil-cooled pistons with two compression rings and one oil scraper ring
- Cast-in grey iron cylinder liners
- Replaceable valve seats
- Six-bearing crankshaft
- Front-end transmission

Engine mounting

- Flexible engine mounting

Lubrication system

- Easily replaceable (insert) full-flow oil filter
- Plate oil cooler

Fuel system

- Common rail fuel injection system
- Piezo-electric injectors
- Constant power output regardless of fuel quality or temperature (5-55°C/41-131°F)

- Fine filter with water separator and water in fuel sensor with alarm

Air inlet and exhaust system

- Replaceable air filter
- Closed crankcase ventilation with oil separator and filter
- Stainless steel exhaust elbow
- Turbocharger with variable geometry

Cooling system

- Thermostatically regulated freshwater cooling
- Tubular heat exchanger with separate large volume expansion tank
- Coolant system prepared for hot water outlet
- Easily accessible impeller pump
- Seawater strainer

Electrical system

- 12V one-pole electrical system
- 150A alternator, and integrated temperature compensated charging regulator
- Auxiliary stop button

Instruments/control

- Electronic shift and throttle
- Full range of instrumentation available

Reverse gear

HS45AE Hydraulic – drop center with 8° down angled output shaft. Low Speed as option.

- Ratio 2.43:1 or 2.03:1 (RH/LH)

HS63IVE Hydraulic V-drive. Low Speed as option.

- Ratio 2.48:1 or 1.99:1 (RH/LH).

Accessories

An extensive range of accessories are available. For detailed information, please see the Accessories & Maintenance Parts catalog (www.volvopenta.com).

Option

U.S.C.G./MED (SOLAS) kit available.

Contact your local Volvo Penta dealer for further information. Not all models, standard equipment and accessories are available in all countries. All specifications are subject to change without notice.

The engine illustrated may not be entirely identical to production standard engines.

Technical Data

Engine designation	D3-170 I	D3-200 I	D3-220 I
Crankshaft power, kW (hp)	125 (170)	147 (200)	162 (220)
Propeller shaft power, kW (hp)	121 (165)	143 (194)	157 (213)
Engine speed, rpm	4000	4000	4000
Displacement, l (in ³)	2.4 (146)	2.4 (146)	2.4 (146)
Number of cylinders	5	5	5
Bore/stroke, mm (in.)	81/93.2 (3.19/3.67)	81/93.2 (3.19/3.67)	81/93.2 (3.19/3.67)
Compression ratio	16.5:1	16.5:1	16.5:1
Dry weight with HS45AE, kg (lb)	301 (664)	301 (664)	301 (664)
Dry weight with HS63IVE, kg (lb)	335 (739)	335 (739)	335 (739)

Duty rating: R5

Technical data according to ISO 8665. With fuel having an LHV of 42,700 kJ/kg and density of 840 g/liter at 15°C (60°F).

Merchant fuel may differ from this specification which will influence engine power output and fuel consumption.

The engine complies with IMO NOx (D3-200 & D3-220) and the comprehensive emission requirements EU RCD and US EPA Tier 2.

Prepared to meet the upcoming US EPA Tier 3 regulations.

Dimensions D3-170,200, 220/HS45AE

Not for installation

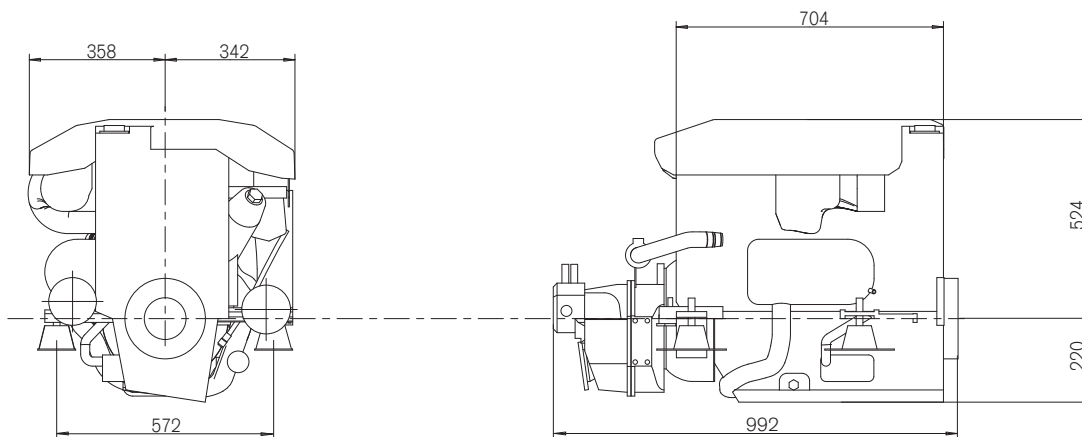

VOLVO PENTA

AB Volvo Penta

SE-405 08 Göteborg, Sweden
www.volvopenta.com